



VCLH-100 (2 rows shelves + Base)

OPEN MERCHANDISERS - FRUIT AND VEGETABLES

Remote Open Front Multideck Merchandiser

Standard features

- Remote Open Merchandiser
- 2 rows shelves + Base
- Steel Shelves
- Externally Equalized TXV
- Thermostat Electronic Control
- Manual Night Curtain
- Epoxy Coated Evaporator
- Price Tag Holder in Front Base Tray
- Aluminium Profile Air Return Grills
- PVC labelling Profiles
- Dixell thermostat with 2 Probes
- 4000k bar led for top canopy
- 4000k bar led for undershelf lighting
- Angled Mirrors On Top Shelf
- Wellington ERC2 Electronic Fan Motor
- Double Glazed Side Wall Left/Right or Solid Side
- Stainless Steel Evaporator Box with Heating Element and Evaporator Cover
- Electrostatic Powdered Paint For Both Interior-Exterior (choice of colors Black or White)

Dimensions

Model	VCLH-100-4	VCLH-100-6	VCLH-100-8	VCLH-100-10	VCLH-100-12
Length (inches)	49"	74"	98"	120"	148"
Width (inches)	40"	40"	40"	40"	40"
BTU per foot	1359	1359	1359	1359	1359
Power	120V 60HZ	120V 60HZ	120V 60HZ	120V 60HZ	120V 60HZ
Amperage	1A	1A	1.5A	1.5A	2A
Evaporating Temp	-5C	-5C	-5C	-5C	-5C

Above mentioned measurement are from internal part of the equipment. Side panel will be extra

Technical Drawings

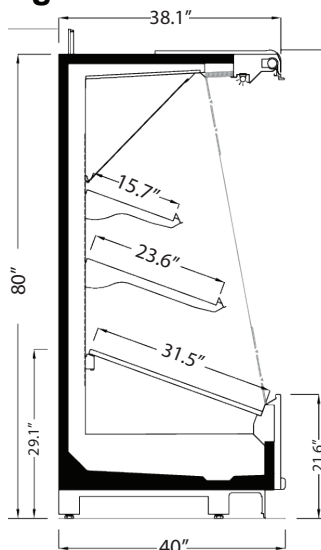

* Customizable options available; * Multiple shelves available; * All measurements are approximates; * Specifications are subject to change without notice; * All equipment are designed to operate in a controlled environment below 75°F (+24°C) temperature and HR 55% relative humidity;

